

# Developments of a Novel Impedance Matching Circuit for Electrically Small Antennas

**K. Yoshida, S. Sakaguchi, S. Oda and H. Kanaya**

Department of Electronics, Graduate School of Information Science and Electrical Engineering, Kyushu University, Fukuoka 812-8581, Japan

e-mail: yoshida@ed.kyushu-u.ac.jp

**Abstract.** In order to reduce the size of a wireless system, we have proposed the design formulas for an electrically small antenna (ESA), i.e. an antenna whose dimension is much smaller than a wavelength, with a miniaturized matching circuit which connects to a 50ohm external circuit. We designed a slot dipole antenna with the aid of the simulations using the electrical circuits as well as the electromagnetic field (EM field) simulator. The size of the designed antenna including the matching circuit is 4.1mm × 1.9mm on MgO substrate with relative permittivity of 9.6 at the center frequency of 5GHz, and the designed fractional bandwidth is 13%@RL=3dB. We also made experiments on the slot dipole type ESA with a matching circuit using YBCO thin films on MgO substrates.

## 1. Introduction

In recent years, the miniaturization of antennas is essential in radio communication devices such as wireless LAN, RF-ID and MIMO, and extensive studies are made of an electrically small antenna (ESA), i.e., the antenna whose dimension is much smaller than a wavelength, towards further reduction of the antenna size[1]-[3]. It is widely known, however, that in order to realize superconducting ESA we must simultaneously realize an impedance matching circuit which compensates the narrow bandwidth peculiar to the superconducting small antenna with low radiation resistance [4]-[6].

In this paper we propose a design theory for the impedance matching circuit which connects an ESA to a 50Ω load. It is shown that the proposed matching circuit has performances similar to that of the n-pole bandpass filter (BPF) [7]. By using the quarter wavelength transmission line and J-inverter, we can reduce the total antenna size more than the previous works. Theoretical performances of the slot dipole antenna with the impedance matching circuit designed by the present theory are studied by the electrical circuits using transmission lines (Transmission Line Model) as well as the EM field simulator. In order to demonstrate the theory, we also carried out experiments on the slot dipole antenna with the matching circuit of pole number  $n = 1$  using high temperature superconductors YBCO on MgO substrates in the 5 GHz band.

## 2. Design Formulas of Impedance Matching Circuit for ESA

Figure 1(b) shows the equivalent circuit for the electrically small slot dipole antenna, whose schematic figure is shown in Fig. 1(a). When the length of the slot is sufficiently smaller than half wavelength, the input impedance of the antenna  $Z_a$  is given by  $Z_a = R_a + j\omega L_a$ , where  $R_a$  is the radiation resistance

and  $L_a$  is the inductance, and  $\omega$  is the angular frequency. In Fig.2 (a) we show the prototype single-pole bandpass filter with  $J$  inverters, where the design formulas are given by [7],

$$J_{0,1} = \sqrt{w} \sqrt{\frac{Y_0 b_1}{g_0 g_1}}, \tag{1}$$

$$J_{1,2} = \sqrt{w} \sqrt{\frac{b_1 Y_0}{g_1 g_2}}, \tag{2}$$

$$B_1 = b_1 \left( \frac{\omega}{\omega_0} - \frac{\omega_0}{\omega} \right), \tag{3}$$

where  $w$  is the fractional bandwidth,  $Y_0$  ( $=1/50 \Omega^{-1}$ ) is the system admittance,  $\omega_0$  is the center frequency,  $g_i$  ( $i=0, 1, 2$ ) is the normalized element value,  $B_1$  is the susceptance for parallel-resonance and  $b_1$  is its slope parameter. In Fig. 2(b) we show the equivalent circuit for the matching circuit which is the analogue of Fig. 2(a). The input admittances seen from the left of  $J_{1,2}$ ,  $Y$  and  $Y'$ , as shown in Figs. 2(a) and 2(b), are given by

$$Y = \frac{b_1}{Q_{e1}} + jB_1, \tag{4}$$

$$Y' = \frac{Z_{01} + jZ_a \tan \theta}{Z_{01}(Z_a + jZ_{01} \tan \theta)} = G' + jB', \tag{5}$$

where  $Q_{e1} = g_0 g_1 / w$ ,  $Z_{01}$  is the characteristic impedance of the transmission line with length  $l$ ,  $G'(\omega, \theta) = \text{Re}(Y')$ ,  $B'(\omega, \theta) = \text{Im}(Y')$ ,  $\theta = \omega \sqrt{LC}l$  is the electrical length, whose value is slightly smaller than  $\pi/2$ , i.e.,  $l$  is nearly equal to quarter wavelength.

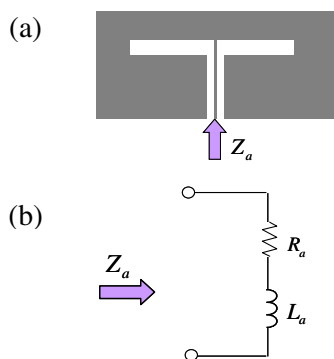

Fig.1 (a) Schematic of electrically small dipole antenna, (b) its equivalent circuit

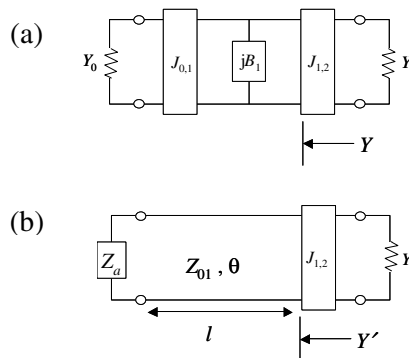

Fig.2 (a) Prototype single pole bandpass filter with  $J$  inverters, (b) proposed matching circuit for ESA.

The conditions that  $Y=Y'$  near the resonant frequency  $\omega_0$  are given by

$$B'(\omega_0, \theta_0) = 0, \tag{6}$$

$$G'(\omega_0, \theta_0) = \frac{b_1}{Q_{e1}} \tag{7}$$

$$b_1 = \frac{\omega_0}{2} \left. \frac{dB'(\omega, \theta)}{d\omega} \right|_{\omega=\omega_0} = \frac{\omega_0}{2} \left. \frac{\partial B'}{\partial \omega} \right|_{\omega=\omega_0} + \frac{\theta_0}{2} \left. \frac{\partial B'}{\partial \theta} \right|_{\theta=\theta_0} = \frac{\pi}{4} Z_{01}^{-1}, \tag{8}$$

where  $\theta_0 = \omega_0 \sqrt{LC}l$  is the electrical length at the center frequency.

From Eqs. (6)-(8), we obtain the design formulas for  $\theta_0$ , and  $Z_{01}$  as

$$\theta_0 = \frac{1}{2} \text{Sinc}^{-1} \left( \frac{Q_a}{2Q_{e1} - Q_a} \right), \quad (9)$$

$$Z_{01} = X_a \tan \theta_0, \quad (10)$$

where  $Q_a = X_a / R_a$ ,  $X_a = \omega_0 L_a$ , where  $\text{Sinc}(x) = \sin x / x$  is the sampling function,  $Q_a$  is the quality factor of ESA.  $J_{1,2}$  is given by Eq. (2). In the calculation we assumed the condition  $|Z_a| \ll Z_0$ , i.e., the antenna impedance is sufficiently low.

### 3. Experimental Result

In Fig.3 we show the layout of the electrically small slot dipole antenna designed by using the formulas (9), (10). In this layout we also show the photograph of the  $J$ -inverter and meander line. We made experiments on slot dipole antenna using high temperature superconductor YBCO thin films on MgO substrate with relative permittivity of 9.6. This antenna was placed in a vacuum cryostat, and was measured by using coplanar waveguide probes.

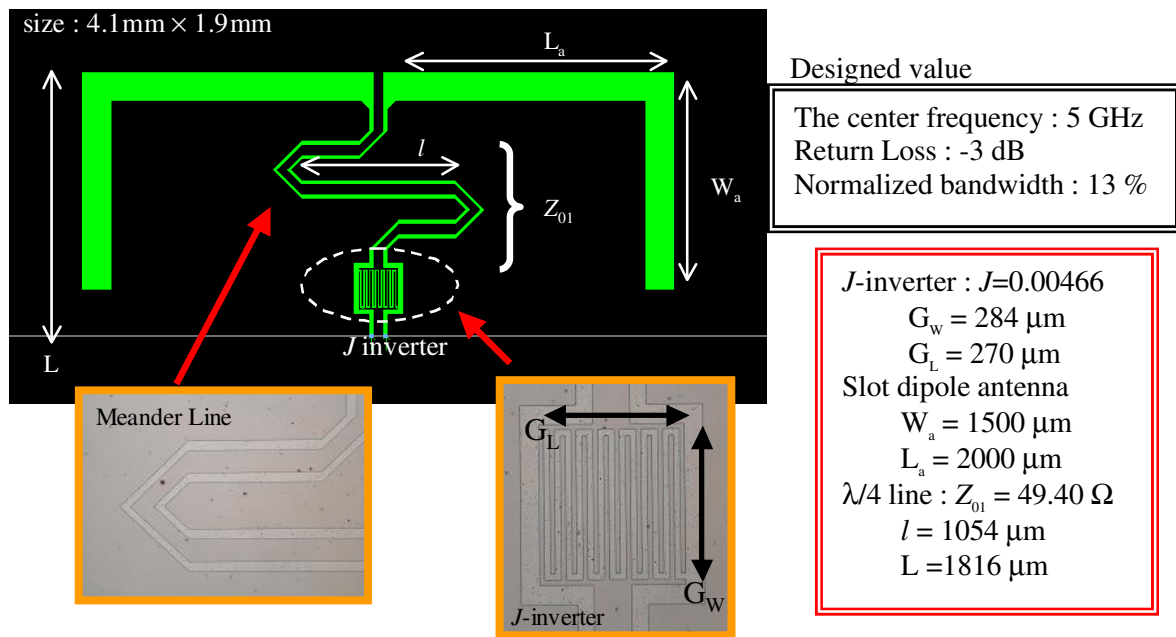

Fig.3 The layout of the slot dipole antenna with matching circuit.

In Figs. 4(a) and 5(a) we show the experimental results for the return loss and the input impedance of the slot dipole antenna with the matching circuit. The frequency response of the slot dipole antenna was measured with vector network analyzer (HP-8722C) at 20K. The values obtained in this measurement include the residual loss due to the contact between the YBCO film and the metal probe. The center frequency is slightly sifted to the lower frequency (4.84GHz) compared to the designed frequency of 5GHz since we neglected the effects of the kinetic inductance of the YBCO. Considering experimental errors due to the over-etching and the residual loss form the contact of the probe, the observed data are in reasonable agreement with simulation results shown in Figs. 4(b) and 5(b).

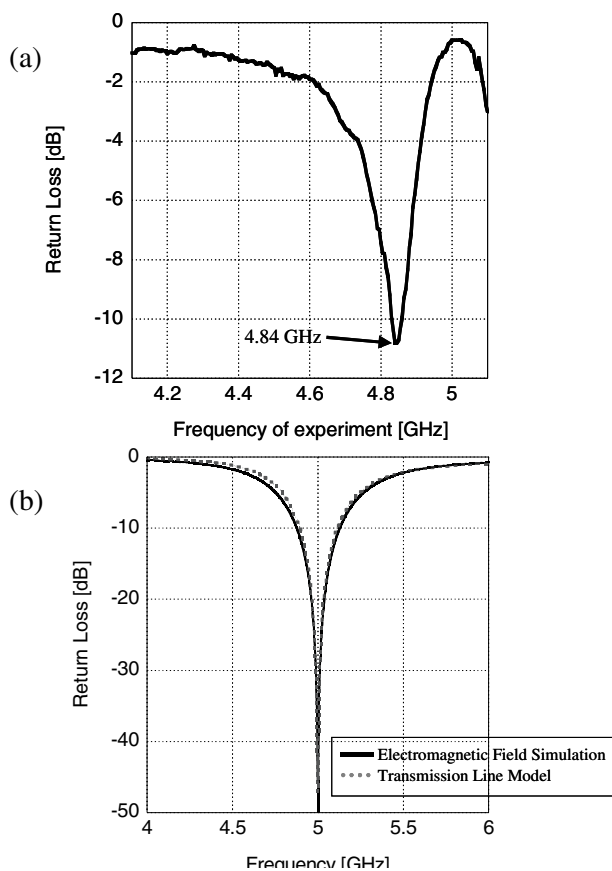

Fig.4 Return Loss (a) Experimental Result, (b) Simulated Result.

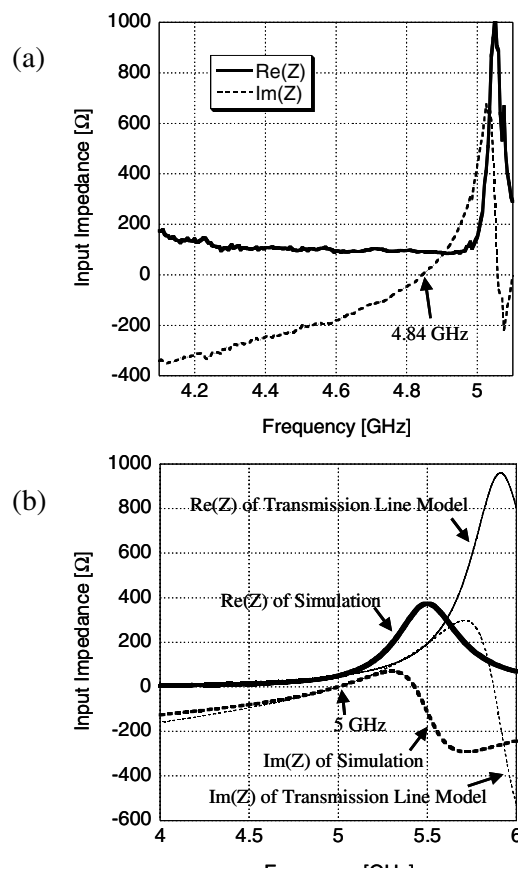

Fig.5 Input Impedance (a) Experimental Result, (b) Simulated Result.

#### 4. Conclusion

We have designed a slot dipole antenna whose dimension is much smaller than a wavelength with miniaturized impedance matching circuits. The impedance matching circuits connect ESA to a  $50 \Omega$  external circuit. The size of the designed antenna with matching circuits is  $4.1\text{mm} \times 1.9\text{mm}$  at the center frequency of 5 GHz and the designed fractional bandwidth of  $13\% @ \text{RL}=3\text{dB}$  on MgO substrate with relative permittivity of 9.6. We also made experiments on the slot dipole antenna with the matching circuit using HTS YBCO thin films on MgO substrates.

#### References

- [1] R. Azadegan and K. Sarabandi 2003 IEEE Trans. Antennas Propagat. 51 421-429.
- [2] M.S.A. Salameh, Y.M.M. Antar, and G. Seguin 2002 IEEE Trans. Antennas Propagat. 50 1415-1419.
- [3] S. Ohshima 2000 Supercond. Sci. Technol. 13 103-108.
- [4] K. Yoshida, T. Takahashi, H. Kanaya, T. Uchiyama, and Z. Wang 2001 IEEE Trans. Appl. Supercond. 11 103-106.
- [5] Y. Tsutsumi, H. Kanaya, and K. Yoshida 2005 IEEE Trans. Appl. Supercond. 15 1020-1023.
- [6] K. Yoshida, Y. Tsutsumi, H. Kanaya 2005 IEICE Trans. Electron. E88-C 1368-1374.
- [7] G. L. Matthaei, L. Young, and E. M. T. Jones 1980 Microwave Filters, Impedance-Matching Networks, and Coupling Structures. (Norwood, MA: Artech House) Chapter 8.